

Drum Pulleys

Drum pulleys are engineered by the professionals at Douglas to be the most durable pulleys in industry. They are developed using a combination of more than 30 years of experience and state of the art computer design and analysis tools.

All Douglas drum pulleys feature our exclusive single piece rolled rim, solid steel pipe or tubing design that ensures long-life, durability and helps ensure proper belt tracking.

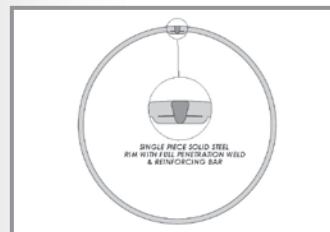
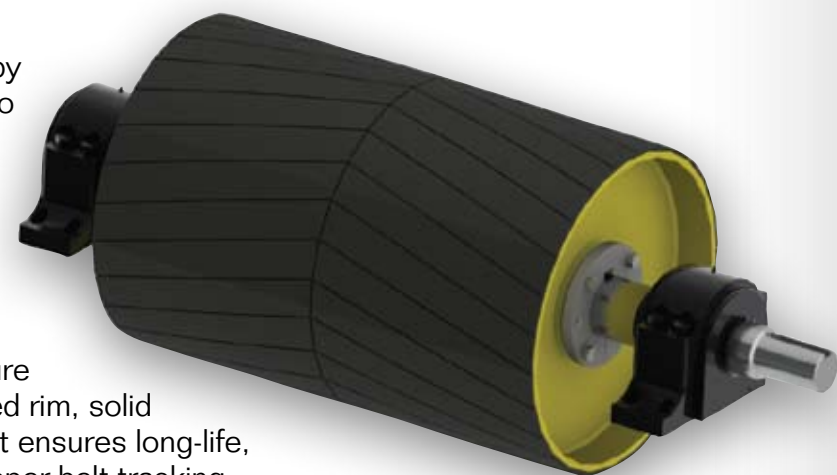

One piece solid steel rims and end discs (see diagram to the left) are welded into a single assembly using the most precise welding methods available to ensure the maximum level of strength and durability.

Rubber lagging is applied in our plant using a state of the art autoclave for maximum bond and total quality control.

Six classes available to suit your specific needs (see inside panel for descriptions)

Heavy Duty	Mine Duty	Pulp and Paper Mill Duty™
Quarry Duty	Extreme Duty	True Engineered Class

XT style hubs and bushings are standard

Keyless Locking Elements, QD Style, HE Style and Taperlock Style available

Lagging styles include:

- Standard Lagging in plain, herringbone/chevron, diamond, spiral or with machined finishes
- Ceramic Lagging for increased lagging life and more traction
- Replaceable Rim Lagging®

INDUSTRIES SERVED INCLUDE:



ALSO AVAILABLE FROM DOUGLAS:

IDLERS

IMPACT BEDS

MAGNETIC SEPARATORS

TAKE-UPS

Contact us 205-884-1200
sales@douglasmanufacturing.com

Or visit our website at
www.douglasmanufacturing.com



Copyright © 2010 Douglas Manufacturing Co., Inc. All Rights Reserved.

CONVEYOR PULLEYS



THE MOST DURABLE CONVEYOR PULLEYS IN INDUSTRY

Douglas Conveyor Pulleys are engineered by the professionals at Douglas to be the most durable pulleys in industry. They are developed using a combination of more than 30 years of experience and state of the art computer design and analysis tools.



Wing Pulleys

Wing Pulleys are engineered by the professionals at Douglas to be the most durable pulleys in industry and are developed using a combination of more than 30 years of experience and state of the art computer design and analysis tools.

The engineered angle of our gussets creates the optimum angle to discharge material away from the pulley and belt and offers enhanced self cleaning ability over other designs.

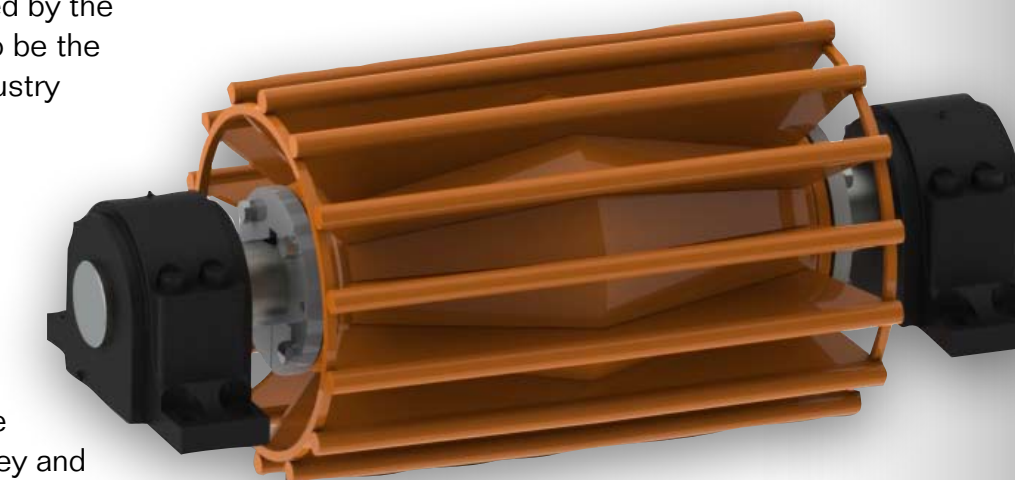

Six classes available to suit your specific needs (see inside panel for descriptions)

Heavy Duty	Mine Duty	Pulp and Paper Mill Duty™
Quarry Duty	Extreme Duty	True Engineered Class

Round Bar Better by Design

- Full 3/4" Thick Minimum Round Contact Bar Can Last 3X Longer
- Helps Prevent Wing Folding
- Round Bar Protects Belt Bottom Cover from Cuts and Tears
- Round Bar Increases Belt Fastener Life
- Self Cleaning Design Discharges Material Helping to Prevent Build Up
- Optional Wing Reinforcing Rings Available

Contact Bar Comparison

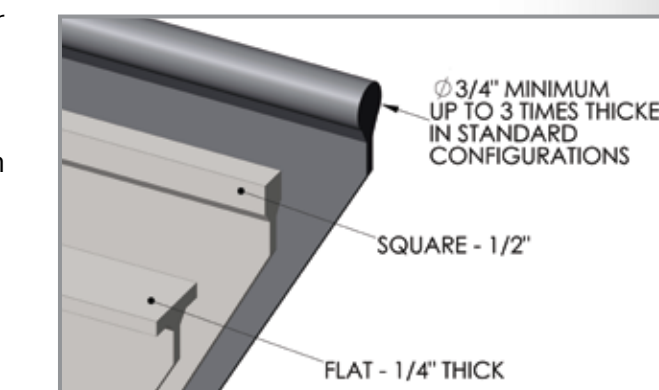

Integra™ Series Drum & Wing Pulleys

Integral Bearing Pulleys Offer Many Performance Benefits

- Up to 33% higher load ratings result from reduced bearing centers
- May be used in all non-drive applications
- Available in drum, self cleaning wing and Vortex™ styles
- Available in Mine Duty & Extreme Duty™ Series
- Integral End disk eliminates chance of hub weld failure centers
- Piloted flanged bearing design simple to install, maintain & repair
- Sealed for life bearings equal less maintenance
- "Off the Shelf" bearing availability reduces down time and cost



1Source™ Systems

Douglas Manufacturing offers professionally designed and assembled conveyor pulley assemblies and drives that help to eliminate field assembly errors and reduce installation time and expense.

The Douglas 1Source™ Group Provides:

- Engineered and Assembled Drives
- Shafting Machined to Customer Specifications
- Conveyor Pulley Lagging in a Wide Range of Materials and Finishes
- Pillow Block Bearings Mounted on the Shaft
- Take-Up Systems Complete with Bearings



The Vortex™ Spiral Clean Pulley

The Vortex Spiral Clean Pulley is an innovative concept in self cleaning pulley design. The cutting edge design is for harsh operating conditions and for those applications where uninterrupted operation is a must.

Design features include:

- More efficient self cleaning ability than standard wing pulleys
- Smoother running, reduced vibration, improves sealing at transfer points, reduces the level of noise commonly associated with wing pulleys
- Spiral design aids in belt tracking by moving the belt gently from the center of the pulley to the opposing edges with equal force
- Unique continuous flight design prevents wing folding
- Abrasion resistant contact bar (standard) extends pulley life by as much as 50% over standard contact bars
- 106 Series Keyless Locking Elements (standard) allow for infinite placement on the shaft, transfer torque more efficiently than standard keyed bushings



Vortex™ Spiral Clean pulley with AR bar, optional XT Style bushings and in house machined shaft.



Ceramic Pulley Lagging

Douglas® Ceramic Pulley Lagging delivers substantially increased traction over conventional pulley lagging. Durable ceramic tiles last longer than standard rubber lagging resulting in a reduction in the number of times the pulley must be changed over the life of the conveyor system.

- As much as twice the coefficient of friction over non lagged pulleys
- As much as 50% higher coefficient of friction over standard rubber lagging
- Virtually eliminates belt slippage
- Improves belt tracking
- Easily sheds water and dirt
- Lower belt tension and less take-up weight increases life of components and belt



Quarry Duty Ceramic Lagged pulley with XT style hubs and bushings and in house machined shaft.



Grade 2 Ceramic Lagging features 5/8" thick rubber with patented ceramic tiles permanently bonded inside the rubber.

Vulcanized Pulley Lagging

Douglas® Truck Tire Tuff™ Conveyor Pulley Lagging delivers increased traction and pulley life over non lagged pulleys. Increased traction between the pulley face and the belt bottom cover reduces belt slippage and helps to improve belt tracking. Vulcanized rubber lagging protects the pulley's face from wear and extends pulley service life. Lagging is applied in our plant for total quality control.

- As much as 50% increase in coefficient of friction over non lagged pulleys
- Protects pulley face from wear and extends pulley service life
- Herringbone and Diamond Grooves shed water and dirt promoting a self-cleaning effect
- Improves Belt Tracking



Rubber Lagging Detail Chart

Standard Thicknesses	Standard Grooving Patterns	Standard Material	Standard Durometer	Special Durometers	Special Materials
1/4", 3/8", 1/2", 3/4"	Plain Wrap Impression*, Herringbone**, Diamond	SBR	60-65 Shore A	40, 80	MSHA, Nitrile, Neoprene, EPDM, SCOF, Tan Neoprene

*+/- 1/8" on rubber thickness & no concentricity tolerance guaranteed, natural variations in material thicknesses are normal. Machined finish lagging is available for specific tolerance requirements

**Specify direction of rotation if Douglas is to install shafting – Groove will normally run with the apex of the pattern leading



Diamond Groove



Herringbone / Chevron Groove

Engineering Services

The following engineering and value added services are available from Douglas:

- Conveyor pulley design from basic conveyor data
- Design of complete conveyor drives including motors and reducers
- Certified assembly and manufacturing drawings
- Problem solving analysis for troubled conveyors using state of the art software including our own Conveyor Design Wizard®
- Conveyor surveys for pulley spares optimization
- Maintenance and Operations Seminars



Six Classes of Pulleys Each Engineered to Suit a Specific Need

Heavy Duty (CEMA Class) — Industry standard class built to CEMA standards (B105.1-2009 Specifications for Welded Steel Conveyor Pulleys & B501.1-2003 Specifications for Welded Steel Wing Pulleys) suited to a wide variety of applications especially where initial cost is the most important factor. This class is recommended for use with up to 220PIW conveyor belts.

Mine Duty — Designed to Douglas' proprietary specifications and constructed for increased durability using thicker steel at the rim and end discs. This class of pulley may be applied to all types of mining applications and others where increased service life and safety factors are preferred over initial cost. This class is recommended for use with up to 330PIW conveyor belts.

Pulp and Paper Mill Duty™ — Designed to Douglas' proprietary specifications and constructed for increased durability using thicker steel at the rim and end discs. This class of pulley may be applied to the Forest Products Industry where increased life is preferred over initial cost. This class is recommended for use with up to 330PIW conveyor belts.

Quarry Duty — Designed to Douglas' proprietary specifications and constructed of heavier materials than the Mine Duty Class making it more durable and longer lasting especially where abrasion and increased load effect pulley life. This class of pulley is applied to quarries and aggregate mining facilities where total cost of ownership is a critical factor. This class is recommended for use with up to 600PIW conveyor belts.

Extreme Duty™ — The heaviest class of standard pulley available and is built to Douglas' proprietary specifications including the use of thicker rim and end disc materials, special welding procedures and additional center discs. May also use Integral End Disc Technology. This class of pulley is selected and applied into most mining applications where down-time must be minimized and increased service life is a critical factor. This class is recommended for use with up to 600PIW conveyor belts.

True Engineered Class™ — Designed specifically for the most challenging applications by the Douglas Engineering Department. The design is based on application data provided by the customer. Pulley design including rim selection, end disc configuration and shaft size are selected by Douglas engineers specifically for a specific conveyor application.