

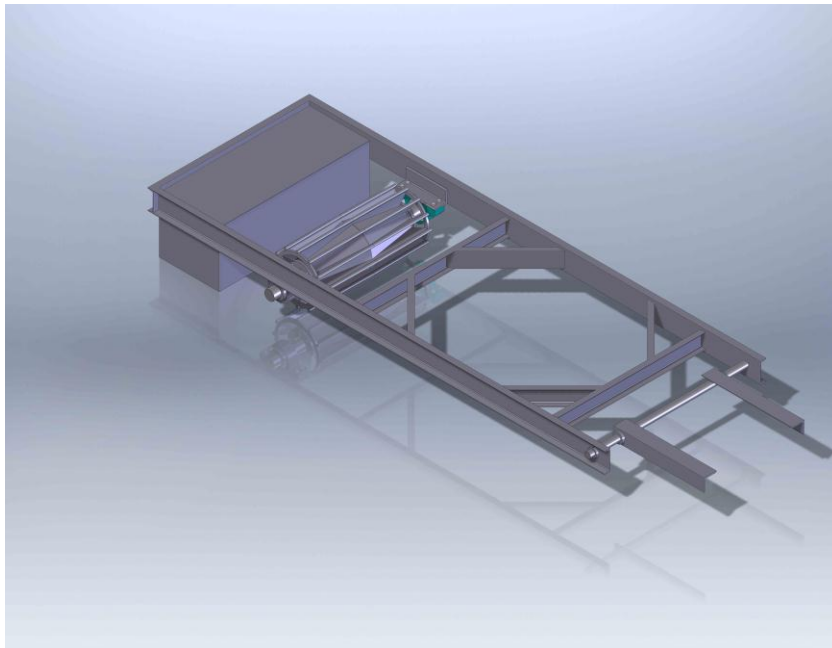

Safety, Operation, & Maintenance Manual

Douglas Scissor Pivot Take-Up



Warning: This manual must be read, understood, and followed by anyone that installs, operates, and maintains this product. Failure to follow instructions may result in serious or fatal injury.

Douglas Manufacturing Co., Inc.

300 Industrial Park Drive, Pell City, Alabama 35125 • Tel: (205) 884-1200 • Fax: (205) 884-1206

Email: sales@douglasmanufacturing.com

SAFETY INFORMATION

1. Follow all federal, state, local and owner recommended safety guidelines.
2. Before beginning work on a conveyor always lockout and tag-out the equipment. Follow all OSHA and other guidelines that pertain to lockout and tag-out procedures.
3. Do not allow anyone to attempt installation on the conveyor or attempt to operate the conveyor until they have read this manual thoroughly and understand it completely.
4. Only workers who are safety trained and familiar with the mechanics and mechanical nature of conveyors and rigging for unloading should work on or around conveyors.
5. Use only safety trained, certified and licensed electricians for all electrical requirements.
6. When loading or unloading the Scissor Pivot Take-Up make sure that you are away from power lines and use caution to prevent metal equipment from contacting power lines.
7. Do not wear loose clothes, jewelry or neckties when working on or around conveyors. Long hair should be secured under a cap or bandana to prevent injury. The moving parts of a conveyor may catch loose clothes, jewelry, neckties or long hair and may result in serious injury.
8. Never operate a conveyor without guards in place. If, in your specific application a moving part is accessible, always cover with expanded metal or other suitable safety cover. Some conveyors are supplied without guards per customer request. It is the customer's responsibility to install proper guards that adhere to local, state and federal requirements and promote safety in the operation of the conveyor.
9. Never allow anyone to ride on a conveyor.
10. Before starting the conveyor make sure that no one is exposed to the moving parts or material being discharged. The speed of the conveyor and the material being conveyed is sufficient to cause bodily injury.
11. If you attempt to weld on a conveyor, disconnect all power sources and connect to a suitable ground point as close to the welding area as possible.
12. Periodically check the conveyor to verify that all safety devices supplied by Douglas Mfg. Co., Inc. or supplied by the customer are in place and working correctly. Do not attempt to use a conveyor that has missing safety devices or safety devices that are not functioning properly.

13. Always replace worn components with factory recommended components.
14. Safety is the responsibility of all concerned. Be aware and alert at all times. Report unsafe conditions to the owner as soon as possible and always take improperly maintained or malfunctioning equipment out of service until such time as it may be properly serviced and returned to normal, safe operating conditions.

INSTALLATION

Douglas Mfg. Co., Inc. is not an installation contractor. These instructions are intended to provide complete and detailed instructions for the installation of your Scissor Pivot Take-up only. Follow all instructions and directions given by the project engineer or contractor responsible for installation.

Tighten all pulley-bushing bolts. Tighten all bearing and idler bolts. Secure all safety guards and safety stop switches.

SCISSORS PIVOT TAKE UP™ ASSEMBLY

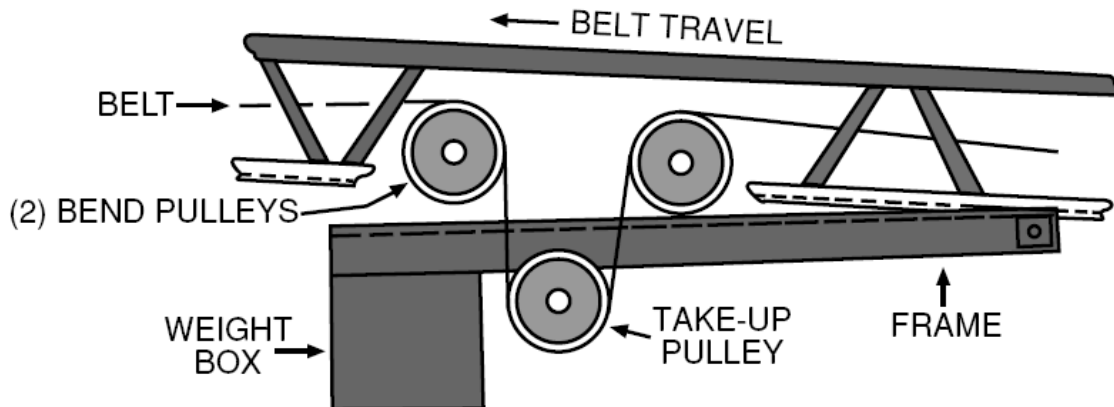

The Scissors Pivot Take Up™ Assembly is a unique design that allows the user to enjoy the benefits of a gravity take up assembly without the problems normally associated with a ground supported take up.

Follow all federal, state, local and owner recommended safety guidelines. Before beginning work on a conveyor always lockout and tag-out the equipment. Follow all OSHA and other guidelines that pertain to lockout and tag-out procedures.

Make sure that the farthest length of the frame in a downward position is at least 8' from ground level. This is the minimum MSHA recommended distance. It is preferred that the area under the take up is kept clear and fenced off in case of loose swinging weight from arm.

Weld or bolt the take up frame to the conveyor frame making sure that the bend pulleys are perfectly squared with the conveyor frame on all planes.

Do not locate The Scissor Pivot Frame in close proximity to conveyor support structures. If the STU Take-Up frame should become free from its restraints, it can generate enough force to significantly damage nearby support structures.

Permanently attach supplied safety chains from the conveyor frame to the weight frame arm to support weight from arm in case of belt breakage. The proper location of the chain eyebolts is the length that will limit travel of the Scissors Pivot Take Up™ to a maximum angle of 45° down off the conveyor frame. On an 8 foot long take up frame arm the needed chain length is 8 foot on each side at the end of the arm.

If the angle exceeds 45° the frame and weight box will pull on the swivel attachment at the conveyor frame and not perform correctly as a take up. Stresses could also result in swivel attachment failure.

A properly installed Scissors Pivot Take Up™ should have a clear span in front of the take up frame and behind the take up frame. A free swinging or loose arc should not be able to strike a support structure, strike the ground or any other object. MSHA approved guards (supplied by the customer) should be attached where necessary to prevent unauthorized or accidental access to moving parts. Determination of the required guards depends on the location of the take up. Guards must be installed by the user to promote safety. Do not operate the unit without user supplied guards in place.

When attaching the bend pulley pillow blocks to the conveyor frame do not install them upside down. This is referred to as “cap loading” and may result in bearing housing failure. Grease all bearings per bearing manufacturer instructions. Tighten all pulley shaft housings.

Tie off the Scissors Pivot™ Take Up Frame in a position so that the center of the take up pulley is 12 inches to 24 inches from the center of the bend pulleys. String and splice the belt with the take up frame in this position.

Verify that the safety chains are attached. Verify that all personnel are safely removed from the work area and slowly release any constraints on the take up frame so that assembly is ready to function.

Be sure that personnel and equipment are clear of the conveyor and take up frame before starting the conveyor.

Safety is the responsibility of all concerned. These instructions cannot cover every situation that may occur. Be aware and alert for any situation that may present a safety problem and report it to the appropriate person immediately.

GENERAL MAINTENANCE

Proper maintenance and care will help ensure that your conveyor provides years of long, trouble free life. Regular inspection, lubrication, adjustment and maintenance will help prevent breakdown situations. Installed QD or XT pulley bushings need to be inspected and retightened in accordance with the attached specification sheets.

REQUIRED DAILY MAINTENANCE

Check for any safety hazards. Make sure that all guards are in place. Check for loose bolts, etc. and check mechanical joints.

Listen for unusual sounds and check for unusual vibrations.
Check for proper belt travel.

REQUIRED WEEKLY MAINTENANCE

Inspect for worn parts and replace well in advance of failure to prevent costly downtime and interruptions in production.

Inspect belt, vulcanized belt splice or mechanical fasteners for wear and repair/replace as needed.

Replace missing or worn out caution labels.

LUBRICATION

Follow all factory recommended procedures in regards to lubrication of the pillow block bearings and flange bearings.

INSTALLATION FLYER

Use the following page as a convenient guide when installing a STU Scissor Pivot Take-up.