



Safety, Operation, & Maintenance Manual

Douglas Ultra Power Manual Cleaning Suspended Magnetic Separators



Warning: This manual must be read, understood, and followed by anyone that installs, operates, and maintains this product. Failure to follow instructions may result in serious or fatal injury.

Douglas Manufacturing Co., Inc.

300 Industrial Park Drive, Pell City, Alabama 35125 • Tel: (205) 884-1200 • Fax: (205) 884-1206

Email: sales@douglasmanufacturing.com

SAFETY INFORMATION

1. Follow all federal, state, and local and owner recommended safety guidelines.
2. Before beginning work on any motorized equipment always lockout and tag-out the equipment. Follow all OSHA, MSHA and in-house guidelines that pertain to lockout and tag-out procedures.
3. Do not allow anyone to attempt installation or operation of this unit until they have read this manual thoroughly and understand it completely.
4. Only personnel who are safety trained and familiar with the mechanics and mechanical nature of conveyors, and rigging for unloading, should work on or around this unit.
5. When loading or unloading these units ensure that you are away from power lines and use caution to prevent metal equipment from contacting power lines.
6. Do not wear loose clothes, jewelry or neckties when working on or around this unit. Long hair should be secured under a cap or bandana to prevent injury. The moving parts of a nearby belt conveyor may catch loose clothes, jewelry, neckties or long hair and may result in serious injury.
7. It is the customer's responsibility to install proper guards that adhere to local, state and federal, and in-house requirements to promote safety in the operation of this unit.
8. Welding is not allowed on this type of Magnetic Separator.
9. Periodically check this Magnetic Separator to verify that safety decals are in place. It is the owner's responsibility to replace missing, worn and/or faded decals as required.
10. Always replace worn components with factory recommended components.
11. Safety is the responsibility of all concerned. Be aware and alert at all times. Report unsafe conditions to the owner as soon as possible and always take improperly maintained or malfunctioning equipment out of service until such time as it may be properly serviced and returned to normal, safe operating conditions.
12. Please feel free to contact Douglas Manufacturing if you have any questions concerning your Cross Belt Magnetic Separator.

MODEL XMG INSTALLATION INSTRUCTIONS

- When installing your XMG cross belt magnet, make sure there is enough clearance to properly clean and maintain it for efficient operation.
- Preferred installation of this magnet is over the trajectory of material discharged from a belt conveyor. This is referred to as a position 1 installation (see illustration below).
- If a trajectory well away from the belt is developed, this is the best way to utilize the full potential of the separator since the material being treated is moving directly toward the magnet face. Its momentum assists the separation of iron. At slower conveyor speeds, as the trajectory of the discharge material becomes more nearly vertical, magnet position must be shifted back more nearly over the head pulley. At slow belt speeds a non-ferrous (stainless steel) head pulley may be required for effective separation.
- An installation with the separator over the moving bed of material before the discharge point of the conveyor is referred to as a position 2 installation (see illustration below). Position 2 mounting is not recommended where belt speeds are excessive.

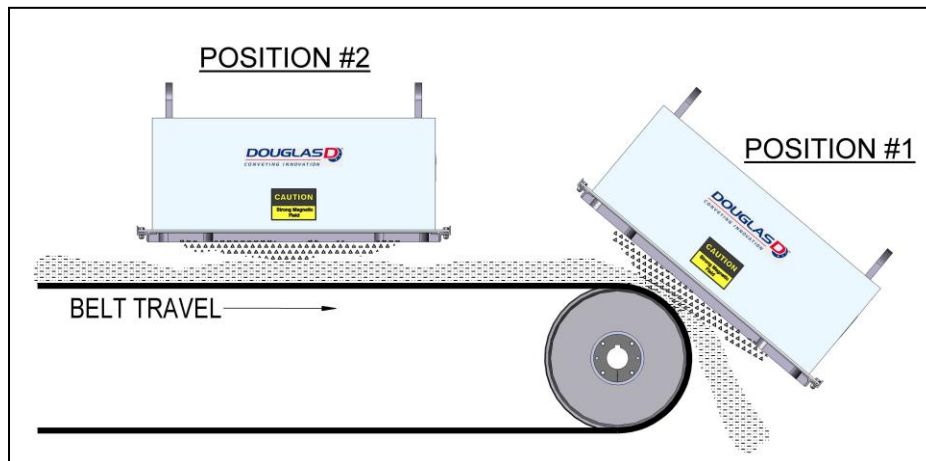

- Install the cross belt magnet in a frame with rated lifting chain to hold the magnet as required over the conveyor. The frame design should be according to an engineer's general arrangement drawing. The magnet is permanent so no electrical power is required.
- Never install with face of magnet more than 11 inches from face of magnet to belt top cover centerline unless approved in writing by Douglas Manufacturing. Install the magnet so that the face of the magnet is as close as possible to the product flow on the conveyor. Mounting height is critical to magnet performance.

If you have any questions about the operation of your cross belt magnet, call Douglas Manufacturing at any time during normal business hours.

Thank you for choosing a Douglas Cross Belt Magnetic Separator. We want it to give you years of low cost and safe service.

DECAL LOCATIONS

If during routine inspections you discover missing items such as the name plate, logos, and caution or warning decals please contact Douglas Manufacturing as soon as possible to request replacements. Use the diagram below when you are ready to reattach them.

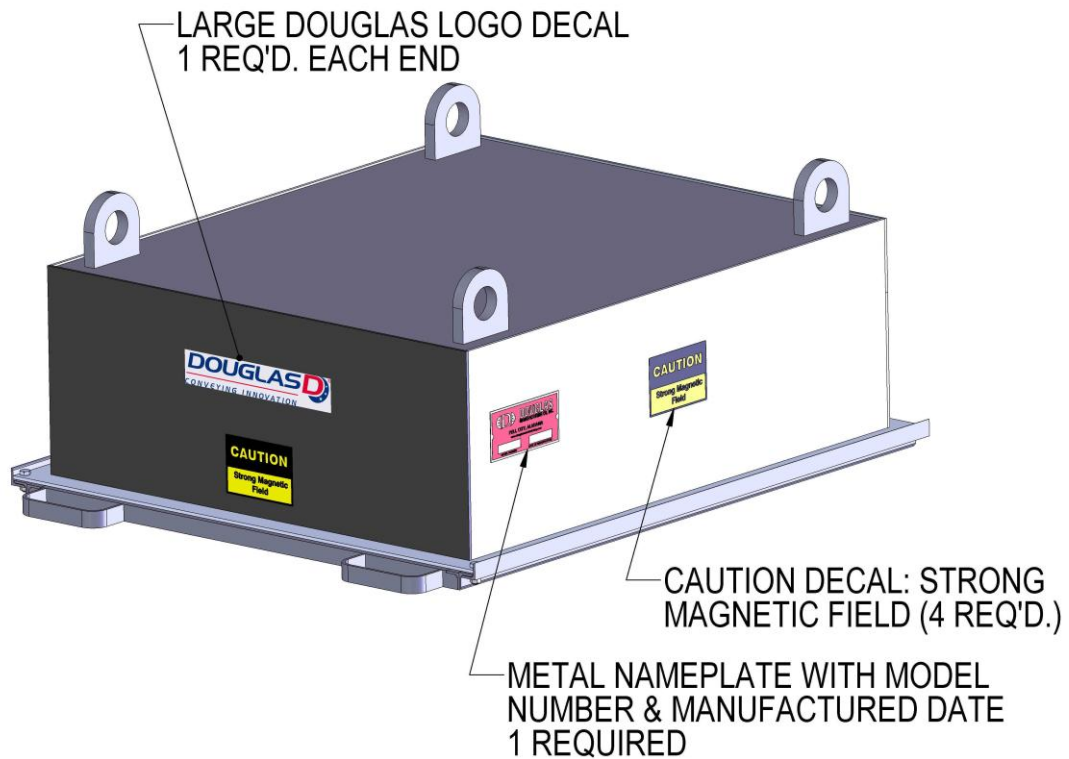

Operation & Maintenance:

- The ferrous tramp metal item(s) will be collected either on the magnet face or on the bottom of the cleaning drawer (if so equipped). In either case it is necessary to periodically remove the accumulated tramp metals by hand picking or using the optional cleaning drawer.
- When using the optional cleaning drawer to remove tramp metal items please follow these recommendations:

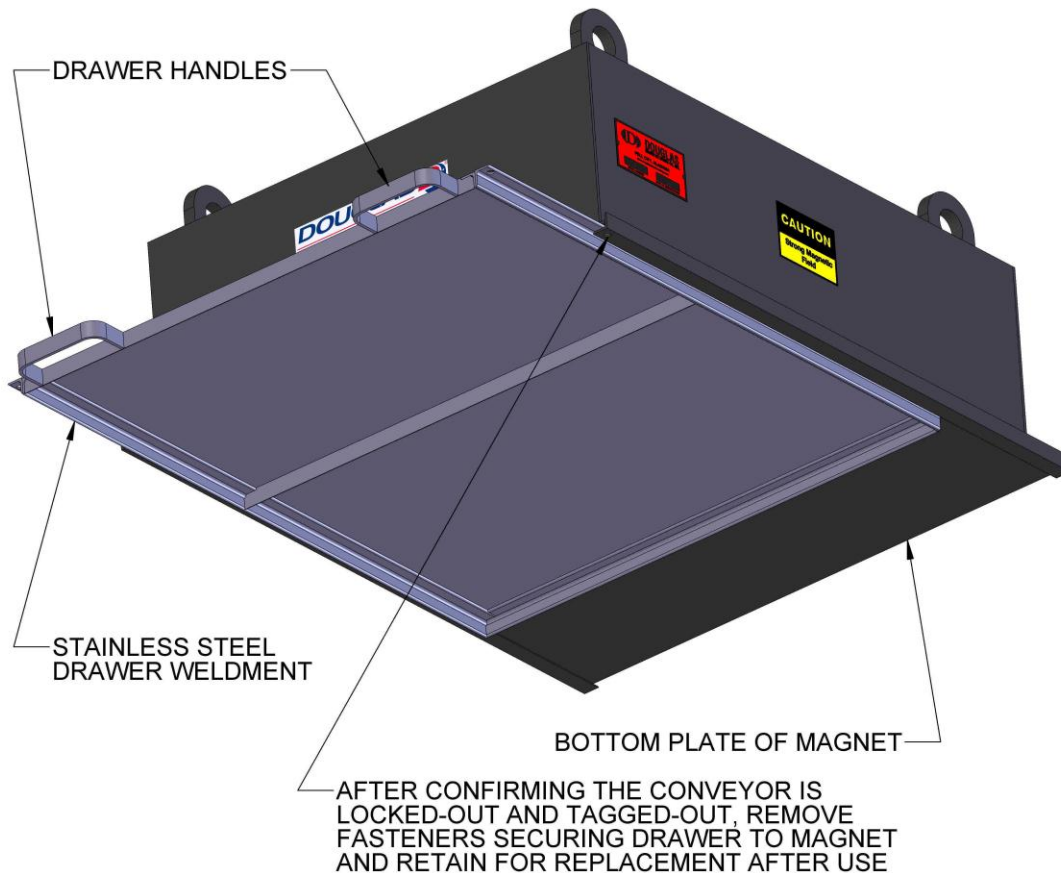

- Before periodic cleaning of the magnet face follow all OSHA, MSHA and in-house guidelines pertaining to conveyor lockout and tag-out procedures.
- Have a waste container with you before you begin cleaning using the optional cleaning drawer.
- Slowly pull the cleaning drawer out from under the magnetic separator and carefully remove the collected ferrous items. Use extreme caution as some items may release prematurely.

- Inspect the magnetic separator assembly on a regular basis and take note of excessive distortion or wear of the bottom plate or optional cleaning drawer. Consider replacing the unit and other attachments if you notice any of these issues.
- There are serviceable internal parts of the magnetic separator itself. The optional cleaning drawer, fasteners, decals, logos, and nameplate are available by contacting Douglas.