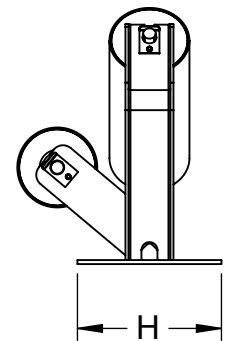
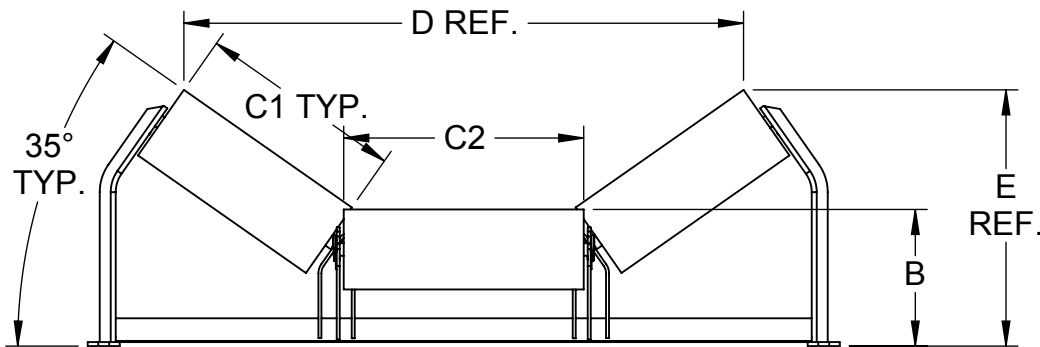
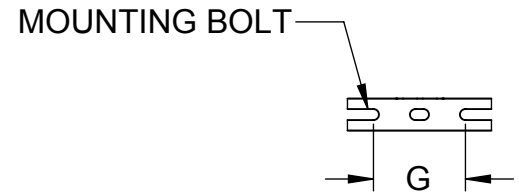
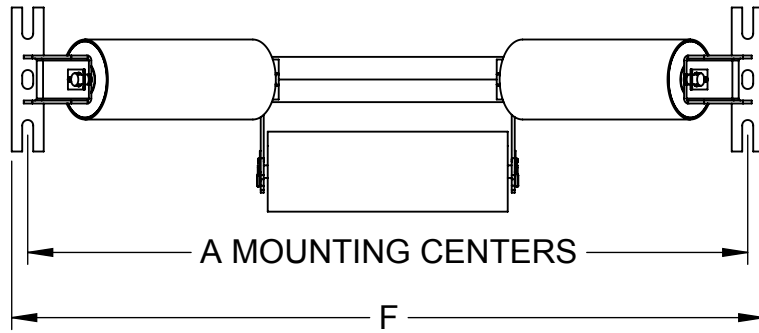

CEMA B 20° OFFSET CENTER ROLL TROUGH IDLER 4" DIAMETER ROLLS

BELT WIDTH	MODEL NO.	WT.	A	B	C1	C2	D	E	F	G	H	MOUNTING BOLT
18	DBO-18-20-04	29	27	7 1/16	6 5/8	7 5/8	20 11/16	9 1/2	29	6	7 1/2	1/2
20	DBO-20-20-04	31	29	7 1/16	7 1/4	8 1/4	22 1/4	9 3/4	31	6	7 1/2	1/2
24	DBO-24-20-04	34	33	7 1/16	8 11/16	9 11/16	26 5/8	10 1/4	35	6	7 1/2	1/2
30	DBO-30-20-04	40	39	7 1/16	10 15/16	11 15/16	33 1/8	11 1/16	41	6	7 1/2	1/2
36	DBO-36-20-04	49	45	7 1/16	12 15/16	13 15/16	38 7/8	11 3/4	47	7 1/2	9	5/8
42	DBO-42-20-04	55	51	7 9/16	14 15/16	15 15/16	44 5/8	12 13/16	53	7 1/2	9	5/8
48	DBO-48-20-04	61	57	7 9/16	16 15/16	17 15/16	50 7/16	14 1/8	59	7 1/2	9	5/8

CEMA B 20° OFFSET CENTER ROLL TROUGH IDLER 5" DIAMETER ROLLS

BELT WIDTH	MODEL NO.	WT.	A	B	C	C2	D	E	F	G	H	MOUNTING BOLT
18	DBO-18-20-05	29	27	7 9/16	6 5/8	7 5/8	20 11/16	9 1/2	29	6	7 1/2	1/2
20	DBO-20-20-05	31	29	7 9/16	7 1/4	8 1/4	22 1/4	9 3/4	31	6	7 1/2	1/2
24	DBO-24-20-05	34	33	7 9/16	8 11/16	9 11/16	26 5/8	10 1/4	35	6	7 1/2	1/2
30	DBO-30-20-05	40	39	7 9/16	10 15/16	11 15/16	33 1/8	11 1/16	41	6	7 1/2	1/2
36	DBO-36-20-05	49	45	7 9/16	12 15/16	13 15/16	38 7/8	11 3/4	47	7 1/2	9	5/8
42	DBO-42-20-05	55	51	8 1/16	14 15/16	15 15/16	44 5/8	12 13/16	53	7 1/2	9	5/8
48	DBO-48-20-05	61	57	8 1/16	16 15/16	17 15/16	50 7/16	14 1/8	59	7 1/2	9	5/8

CEMA B 35° OFFSET CENTER ROLL TROUGH IDLER 4" DIAMETER ROLLS

BELT WIDTH	MODEL NO.	WT.	A	B	C1	C2	D	E	F	G	H	MOUNTING BOLT
18	DBO-18-35-04	30	27	7 1/8	6 5/8	7 5/8	18 3/8	11 1/16	29	6	7 1/2	1/2
20	DBO-20-35-04	32	29	7 1/8	7 1/4	8 1/4	20 3/16	11 7/16	31	6	7 1/2	1/2
24	DBO-24-35-04	35	33	7 1/8	8 11/16	9 11/16	23 13/16	12 1/4	35	6	7 1/2	1/2
30	DBO-30-35-04	41	39	7 1/8	10 15/16	11 15/16	29 7/8	13 1/2	41	6	7 1/2	1/2
36	DBO-36-35-04	50	45	7 1/8	12 15/16	13 15/16	35 3/16	14 5/8	47	7 1/2	9	5/8
42	DBO-42-35-04	56	51	7 1/2	14 15/16	15 15/16	40 1/2	16 3/16	53	7 1/2	9	5/8
48	DBO-48-35-04	62	57	7 1/2	16 15/16	17 15/16	44 5/8	17 3/8	59	7 1/2	9	5/8

CEMA B 35° OFFSET CENTER ROLL TROUGH IDLER 5" DIAMETER ROLLS

BELT WIDTH	MODEL NO.	WT.	A	B	C1	C2	D	E	F	G	H	MOUNTING BOLT
18	DBO-18-35-05	33	27	7 5/8	6 5/8	7 5/8	20 3/8	11 1/2	29	6	7 1/2	1/2
20	DBO-20-35-05	35	29	7 5/8	7 1/4	8 1/4	21 15/16	11 7/8	31	6	7 1/2	1/2
24	DBO-24-35-05	39	33	7 5/8	8 11/16	9 11/16	26 1/4	12 11/16	35	6	7 1/2	1/2
30	DBO-30-35-05	45	39	7 5/8	10 15/16	11 15/16	32 3/4	13 15/16	41	6	7 1/2	1/2
36	DBO-36-35-05	55	45	7 5/8	12 15/16	13 15/16	38 9/16	15 1/16	47	7 1/2	9	5/8
42	DBO-42-35-05	61	51	8	14 15/16	15 15/16	44 1/4	16 5/8	53	7 1/2	9	5/8
48	DBO-48-35-05	68	57	8	16 15/16	17 15/16	45 3/16	17 3/4	59	7 1/2	9	5/8

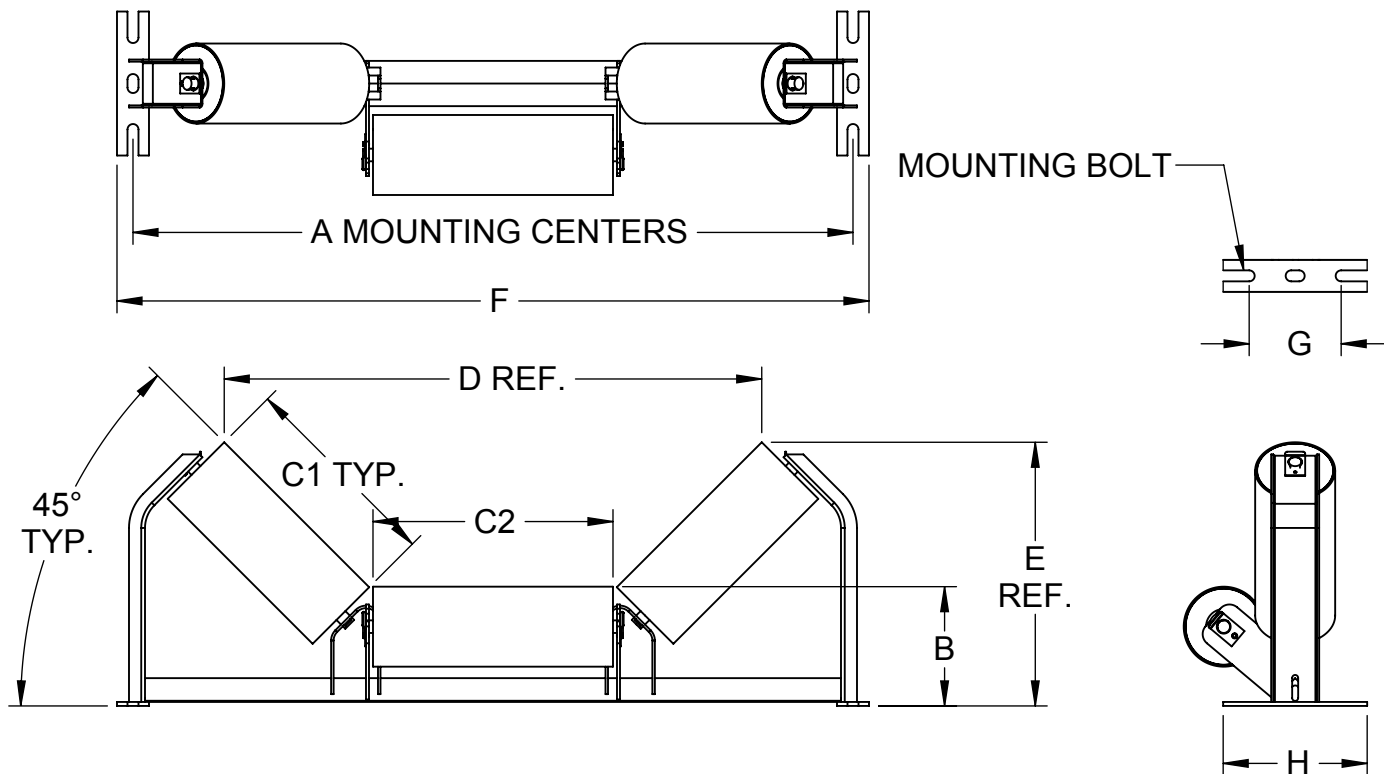
CEMA B 45° OFFSET CENTER ROLL TROUGH IDLER 4" DIAMETER ROLLS

BELT WIDTH	MODEL NO.	WT.	A	B	C1	C2	D	E	F	G	H	MOUNTING BOLT
18	DBO-18-45-04	32	27	6 9/16	6 5/8	7 5/8	18 1/2	11 11/16	29	6	7 1/2	1/2
20	DBO-20-45-04	34	29	6 9/16	7 1/4	8 1/4	20	12 1/8	31	6	7 1/2	1/2
24	DBO-24-45-04	37	33	6 9/16	8 11/16	9 11/16	23 1/2	13 1/8	35	6	7 1/2	1/2
30	DBO-30-45-04	43	39	6 9/16	10 15/16	11 15/16	28 15/16	14 3/4	41	6	7 1/2	1/2
36	DBO-36-45-04	52	45	6 9/16	12 15/16	13 15/16	33 3/4	16 1/8	47	7 1/2	9	5/8
42	DBO-42-45-04	58	51	6 7/8	14 15/16	15 15/16	38 9/16	17 15/16	53	7 1/2	9	5/8
48	DBO-48-45-04	64	57	6 7/8	16 15/16	17 15/16	43 3/8	19 5/16	59	7 1/2	9	5/8

CEMA B 45° OFFSET CENTER ROLL TROUGH IDLER 5" DIAMETER ROLLS

BELT WIDTH	MODEL NO.	WT.	A	B	C	C2	D	E	F	G	H	MOUNTING BOLT
18	DBO-18-45-05	35	27	7 1/16	6 5/8	7 5/8	17 7/8	12 1/16	29	6	7 1/2	1/2
20	DBO-20-45-05	37	29	7 1/16	7 1/4	8 1/4	19 5/16	12 1/2	31	6	7 1/2	1/2
24	DBO-24-45-05	41	33	7 1/16	8 11/16	9 11/16	22 13/16	13 1/2	35	6	7 1/2	1/2
30	DBO-30-45-05	47	39	7 1/16	10 15/16	11 15/16	28 1/4	15 1/8	41	6	7 1/2	1/2
36	DBO-36-45-05	57	45	7 1/16	12 15/16	13 15/16	33 1/16	16 1/2	47	7 1/2	9	5/8
42	DBO-42-45-05	63	51	7 3/8	14 15/16	15 15/16	37 7/8	18 5/16	53	7 1/2	9	5/8
48	DBO-48-45-05	70	57	7 3/8	16 15/16	17 15/16	42 11/16	19 11/16	59	7 1/2	9	5/8