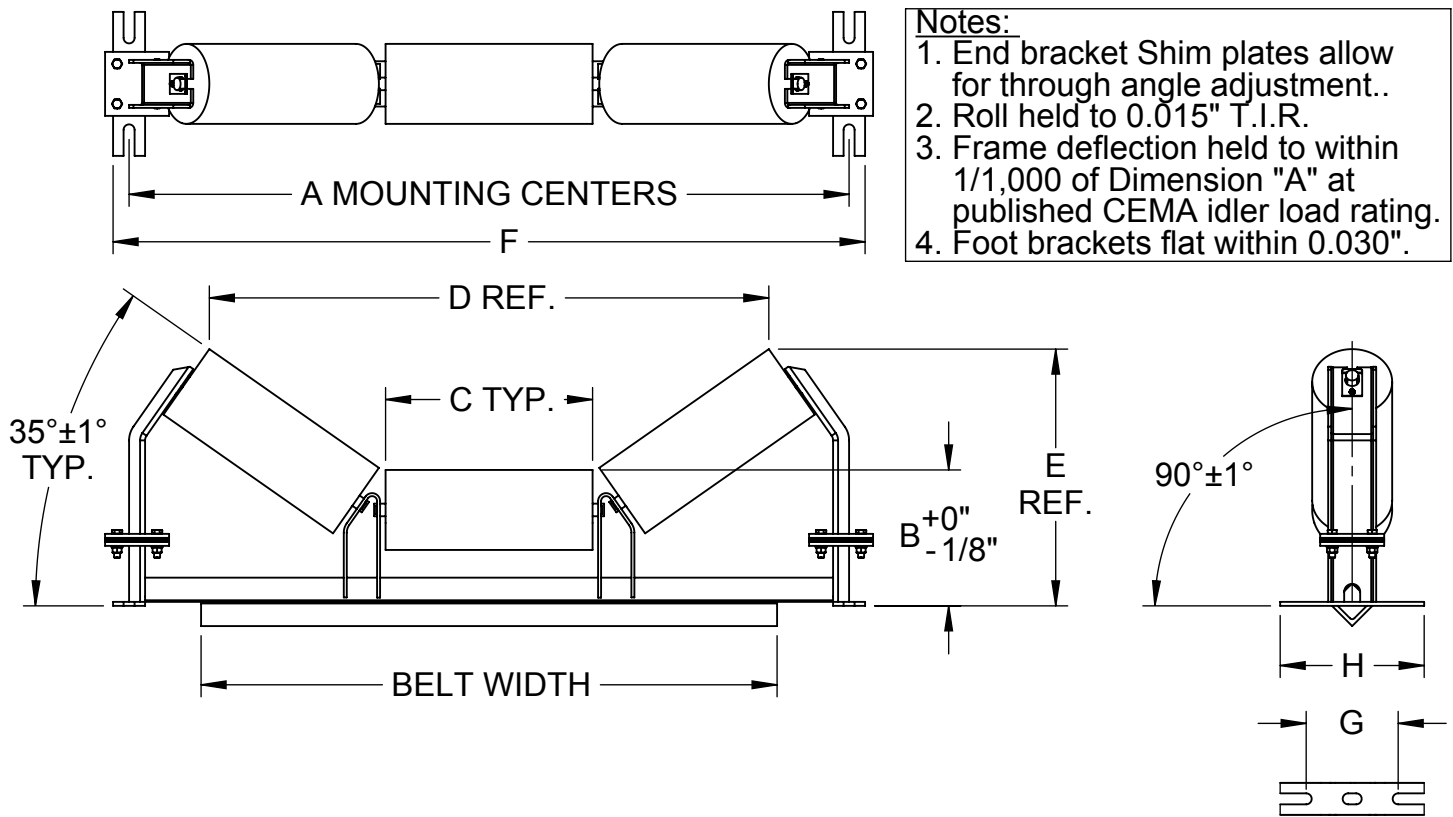

CEMA D 20° SCALE QUALITY TROUGH IDLER 5" DIAMETER ROLLS

BELT WIDTH	MODEL NO.	WT.	A	B	C	D	E	F	G	H	MOUNTING BOLT
24	DDQ-24-20-05	61	33	8 3/8	8 11/16	26 3/8	11 9/16	35	6	7 1/2	1/2
30	DDQ-30-20-05	71	39	8 3/8	10 15/16	32 5/8	12 1/4	41	6	7 1/2	1/2
36	DDQ-36-20-05	81	45	8 3/8	12 15/16	38 1/2	12 7/8	47	6	7 1/2	1/2
42	DDQ-42-20-05	96	51	8 3/4	14 15/16	44 3/16	13 15/16	53	7 1/2	9	5/8
48	DDQ-48-20-05	105	57	8 3/4	16 15/16	49 15/16	14 5/8	59	7 1/2	9	5/8
54	DDQ-54-20-05	123	63	9 3/16	18 15/16	55 11/16	15 3/4	65 1/2	9	11	5/8
60	DDQ-60-20-05	133	69	9 3/16	20 15/16	61 1/2	16 7/16	71 1/2	9	11	5/8
72	DDQ-72-20-05	152	81	9 3/16	20 15/16	73 1/16	18 3/16	83 1/2	9	11	5/8

CEMA D 20° SCALE QUALITY TROUGH IDLER 6" DIAMETER ROLLS

BELT WIDTH	MODEL NO.	WT.	A	B	C	D	E	F	G	H	MOUNTING BOLT
24	DDQ-24-20-06	68	33	8 7/8	8 11/16	26 1/16	12	35	6	7 1/2	1/2
30	DDQ-30-20-06	79	39	8 7/8	10 15/16	32 5/16	12 3/4	41	6	7 1/2	1/2
36	DDQ-36-20-06	90	45	8 7/8	12 15/16	38 3/16	13 5/16	47	6	7 1/2	1/2
42	DDQ-42-20-06	106	51	9 1/4	14 15/16	43 7/8	14 7/16	53	7 1/2	9	5/8
48	DDQ-48-20-06	118	57	9 1/4	16 15/16	49 5/8	15 1/8	59	7 1/2	9	5/8
54	DDQ-54-20-06	136	63	9 11/16	18 15/16	55 3/8	16 1/4	65 1/2	9	11	5/8
60	DDQ-60-20-06	148	69	9 11/16	20 15/16	61 1/8	16 15/16	71 1/2	9	11	5/8
72	DDQ-72-20-06	170	81	9 11/16	20 15/16	72 13/16	18 9/16	83 1/2	9	11	5/8

CEMA D 35° SCALE QUALITY TROUGH IDLER 5" DIAMETER ROLLS

BELT WIDTH	MODEL NO.	WT.	A	B	C	D	E	F	G	H	MOUNTING BOLT
24	DDQ-24-35-05	62	33	8 1/2	8 11/16	23 1/2	13 5/8	35	6	7 1/2	1/2
30	DDQ-30-35-05	72	39	8 1/2	10 15/16	29 5/16	14 15/16	41	6	7 1/2	1/2
36	DDQ-36-35-05	81	45	8 1/2	12 15/16	35	16	47	6	7 1/2	1/2
42	DDQ-42-35-05	96	51	8 1/2	14 15/16	40	17 9/16	53	7 1/2	9	5/8
48	DDQ-48-35-05	106	57	8 7/8	16 15/16	45 3/8	18 3/16	59	7 1/2	9	5/8
54	DDQ-54-35-05	123	63	9 5/16	18 15/16	50 1/2	20 1/4	65 1/2	9	11	5/8
60	DDQ-60-35-05	133	69	9 5/16	20 15/16	55 11/16	21 1/2	71 1/2	9	11	5/8
72	DDQ-72-35-05	153	81	9 5/16	20 15/16	66 9/16	23 5/8	71 1/2	9	11	5/8

CEMA D 35° SCALE QUALITY TROUGH IDLER 6" DIAMETER ROLLS

BELT WIDTH	MODEL NO.	WT.	A	B	C	D	E	F	G	H	MOUNTING BOLT
24	DDQ-24-35-06	68	33	9	8 2/3	22 7/8	14 1/16	35	6	7 1/2	1/2
30	DDQ-30-35-06	80	39	9	10 15/16	28 3/4	15 3/8	41	6	7 1/2	1/2
36	DDQ-36-35-06	90	45	9	12 15/16	35 5/9	15 9/16	47	6	7 1/2	1/2
42	DDQ-42-35-06	107	51	9	14 15/16	39 7/16	17 15/16	53	7 1/2	9	5/8
48	DDQ-48-35-06	118	57	9 3/8	16 15/16	44 5/8	19 3/16	59	7 1/2	9	5/8
54	DDQ-54-35-06	137	63	9 13/16	18 15/16	49 7/8	20 5/8	65 1/2	9	11	5/8
60	DDQ-60-35-06	148	69	9 13/16	20 15/16	55 1/16	21 15/16	71 1/2	9	11	5/8
72	DDQ-72-35-06	170	81	9 13/16	20 15/16	65 9/16	23 15/16	71 1/2	9	11	5/8