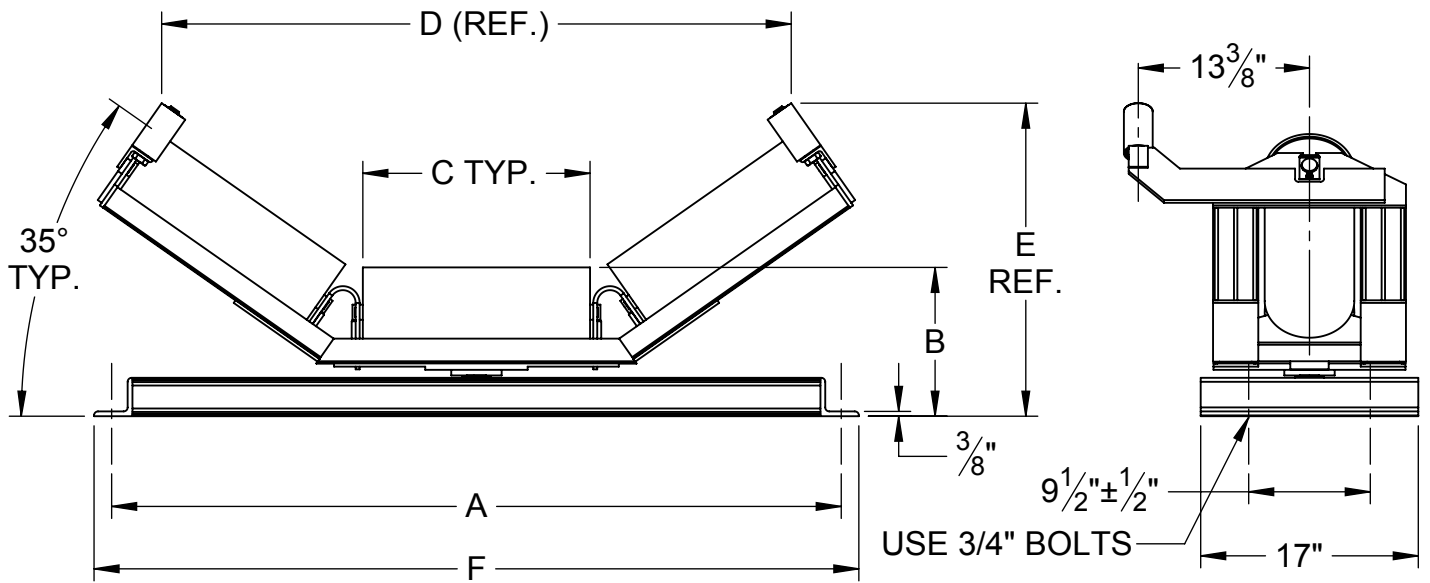

CEMA E 20° SELF-ALIGNING TROUGHING IDLER 6" DIAMETER ROLLS								
BELT WIDTH	MODEL NO.	WT.	A	B	C	D	E	F
36	DES-36-20-06	267	45	11 1/8	12 5/8	40 1/8	18 11/16	47 3/4
42	DES-42-20-06	288	51	11 1/8	14 5/8	45 7/8	19 3/8	53 3/4
48	DES-48-20-06	312	57	11 1/8	17 3/8	53 11/16	20 5/16	59 3/4
54	DES-54-20-06	333	63	11 1/2	19 3/8	59 9/16	21	65 3/4
60	DES-60-20-06	354	69	11 1/2	21 3/8	65	22 5/8	71 3/4
66	DES-66-20-06	376	75	12 3/16	23 3/8	70 7/8	23 1/2	77 3/4
72	DES-72-20-06	399	81	12 3/16	25 3/8	82 1/2	24 5/8	83 3/4
78	DES-78-20-06	420	87	12 3/16	27 3/8	86 1/4	24 1/2	89 3/4
84	DES-84-20-06	441	93	12 3/16	27 3/8	88 1/4	25 5/16	95 3/4
96	DES-96-20-06	483	105	12 3/16	29 3/8	99 3/4	26 5/8	107 3/4

CEMA E 20° SELF-ALIGNING TROUGHING IDLER 7" DIAMETER ROLLS								
BELT WIDTH	MODEL NO.	WT.	A	B	C	D	E	F
36	DES-36-20-07	288	45	11 5/8	12 5/8	40 1/8	18 11/16	47 3/4
42	DES-42-20-07	313	51	11 5/8	14 5/8	45 7/8	19 3/8	53 3/4
48	DES-48-20-07	341	57	11 5/8	17 3/8	53 11/16	20 5/16	59 3/4
54	DES-54-20-07	365	63	12	19 3/8	59 9/16	21	65 3/4
60	DES-60-20-07	390	69	12	21 3/8	65	22 5/8	71 3/4
66	DES-66-20-07	417	75	12 11/16	23 3/8	70 7/8	23 1/2	77 3/4
72	DES-72-20-07	441	81	12 11/16	25 3/8	82 1/2	24 5/8	83 3/4
78	DES-78-20-07	465	87	12 11/16	27 3/8	86 1/4	24 1/2	89 3/4
84	DES-84-20-07	489	93	12 11/16	27 3/8	88 1/4	25 5/16	95 3/4
96	DES-96-20-07	538	105	12 11/16	29 3/8	99 3/4	26 5/8	107 3/4

All dimensions and specifications subject to change without notice.
 Certified dimensions and specifications of ordered material available on request.
 Copyright © 2015, Douglas Manufacturing Co., Inc. All rights reserved.

CEMA E 35° SELF-ALIGNING TROUGHING IDLER 6" DIAMETER ROLLS

BELT WIDTH	MODEL NO.	WT.	A	B	C	D	E	F
36	DES-36-35-06	267	45	11 1/8	12 5/8	36 5/8	21 3/4	47 3/4
42	DES-42-35-06	288	51	11 1/8	14 5/8	41 15/16	22 7/8	53 3/4
48	DES-48-35-06	312	57	11 1/8	17 3/8	49 3/16	24 7/16	59 3/4
54	DES-54-35-06	333	63	11 1/2	19 3/8	54	25 15/16	65 3/4
60	DES-60-35-06	354	69	11 1/2	21 3/8	58 15/16	27 9/16	71 3/4
66	DES-66-35-06	378	75	12 3/16	23 3/8	64 7/8	29 1/16	77 3/4
72	DES-72-35-06	399	81	12 3/16	25 3/8	70 1/16	30 3/16	83 3/4
78	DES-78-35-06	420	87	12 3/16	27 3/8	75 5/16	31 5/16	89 3/4
84	DES-84-35-06	441	93	12 3/16	27 3/8	80 3/4	32 3/8	95 3/4
96	DES-96-35-06	483	105	12 3/16	29 3/8	91 5/16	34 5/8	107 3/4

CEMA E 35° SELF-ALIGNING TROUGHING IDLER 7" DIAMETER ROLLS

BELT WIDTH	MODEL NO.	WT.	A	B	C	D	E	F
36	DES-36-35-07	288	45	11 5/8	12 5/8	36 5/8	21 3/4	47 3/4
42	DES-42-35-07	313	51	11 5/8	14 5/8	41 15/16	22 7/8	53 3/4
48	DES-48-35-07	341	57	11 5/8	17 3/8	49 3/16	24 7/16	59 3/4
54	DES-54-35-07	365	63	12	19 3/8	54	25 15/16	65 3/4
60	DES-60-35-07	390	69	12	21 3/8	58 15/16	27 9/16	71 3/4
66	DES-66-35-07	417	75	12 11/16	23 3/8	64 7/8	29 1/16	77 3/4
72	DES-72-35-07	441	81	12 11/16	25 3/8	70 1/16	30 3/16	83 3/4
78	DES-78-35-07	465	87	12 11/16	27 3/8	75 5/16	31 5/16	89 3/4
84	DES-84-35-07	489	93	12 11/16	27 3/8	80 3/4	32 3/8	95 3/4
96	DES-96-35-07	538	105	12 11/16	29 3/8	91 5/16	34 5/8	107 3/4

All dimensions and specifications subject to change without notice.
 Certified dimensions and specifications of ordered material available on request.
 Copyright © 2015, Douglas Manufacturing Co., Inc. All rights reserved.