

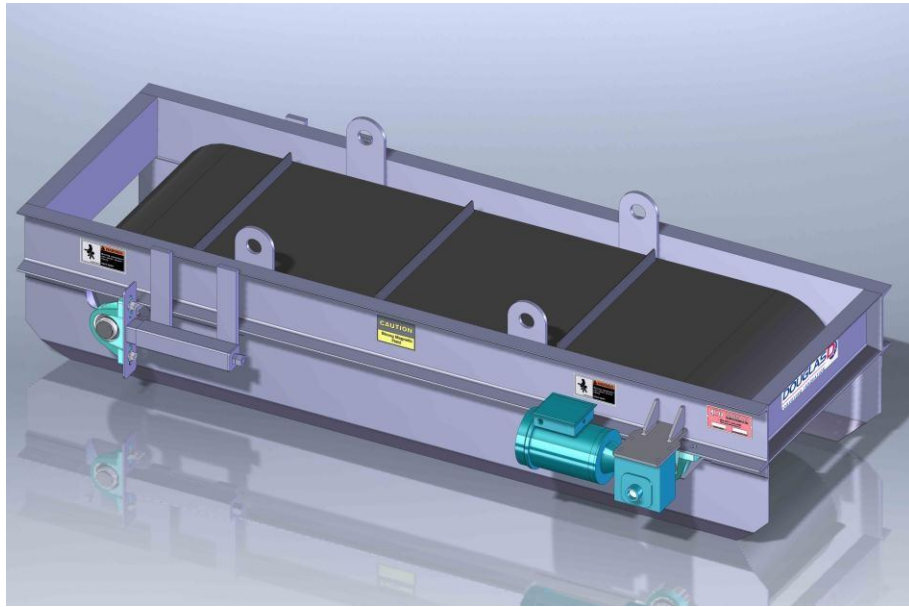

# Safety, Operation, & Maintenance Manual

Douglas CBX Cross Belt Magnetic Separator



Warning: This manual must be read, understood, and followed by anyone that installs, operates, and maintains this product. Failure to follow instructions may result in serious or fatal injury.

**Douglas Manufacturing Co., Inc.**

300 Industrial Park Drive, Pell City, Alabama 35125 • Tel: (205) 884-1200 • Fax: (205) 884-1206

Email: [sales@douglasmanufacturing.com](mailto:sales@douglasmanufacturing.com)

## **SAFETY INFORMATION**

1. Follow all federal, state, and local and owner recommended safety guidelines.
2. Before beginning work on any motorized equipment always lockout and tag-out the equipment. Follow all OSHA, MSHA and in-house guidelines that pertain to lockout and tag-out procedures.
3. Do not allow anyone to attempt installation or operation of this unit until they have read this manual thoroughly and understand it completely.
4. Only personnel who are safety trained and familiar with the mechanics and mechanical nature of conveyors, and rigging for unloading, should work on or around this unit.
5. Use only safety trained, certified and licensed electricians for all electrical requirements.
6. When loading or unloading this unit make sure that you are away from power lines and use caution to prevent metal equipment from contacting power lines.
7. Do not wear loose clothes, jewelry or neckties when working on or around this unit. Long hair should be secured under a cap or bandana to prevent injury. The moving parts of this unit may catch loose clothes, jewelry, neckties or long hair and may result in serious injury.
8. Never operate this unit without guards in place. It is the customer's responsibility to install proper guards that adhere to local, state and federal, and in-house requirements to promote safety in the operation of this unit.
9. It is the customer's responsibility to install a deflector plate at the discharge end of the Ultra Strong Self-Cleaning Magnetic Separator. This is required to prevent injury to personnel passing nearby.
10. Before starting the Magnetic Separator make sure that no one is exposed to the moving parts or materials being discharged. The speed of the cleaned conveyor belt and the material being ejected is sufficient to cause bodily injury.
11. If you attempt to weld on this Magnetic Separator, do so only on the channel frame surrounding the magnet. Be sure to disconnect all power sources and connect to a suitable ground point as close to the welding area as possible.
12. Periodically check this Magnetic Separator to verify that safety guards and decals are in place and working properly. It is the owner's responsibility to replace missing, worn and/or faded decals as required.
13. Always replace worn components with factory recommended components.
14. Safety is the responsibility of all concerned. Be aware and alert at all times. Report unsafe conditions to the owner as soon as possible and always take improperly maintained or malfunctioning equipment out of service until such time as it may be properly serviced and returned to normal, safe operating conditions.
15. Please feel free to contact Douglas Manufacturing if you have any questions concerning your Ultra Strong Cross-Belt Magnetic Separator.

## **CROSS BELT MAGNET INSTALLATION INSTRUCTIONS**

- Head and tail pulleys must be square with the frame before starting. The cross-belt magnet was factory tested and should run true as shipped. Never adjust the head pulley out of square.
- When installing your cross-belt magnet, make sure there is enough clearance to properly clean and maintain it for efficient operation.
- Install the cross-belt magnet in a frame with rated lifting chain to hold the cross-belt magnet over the conveyor. The frame design should be according to an engineer's general arrangement drawing. The lifting chains must not exceed a 45 degree angle to prevent premature failure. Magnet is permanent so no electrical is required except for the drive motor which is normally 3 phase/60Hz 230/460 volts AC.
- Never install with face of magnet more than 11" from face of magnet to belt top-cover at the idler center roll unless approved in writing by Douglas Manufacturing. Install the magnet so that the belt top-cover is as close as possible to the product flow on the conveyor. Mounting height is critical to magnet performance.
- Check the belt take-ups to ensure that they are extended (see figure) to create proper belt tension (the cleated belt must not sag below the edges of the stainless steel rock guards). Also ensure that the bearings are parallel across the width of the unit. The tail pulley centerline must be at 90 degrees to the conveyor frame.
- Check all components and moving parts to make sure they are free to rotate and that all tools and debris have been removed that could prevent their safe rotation.
- Check the oil level in the gearbox. Check bearings for proper lubrication.
- Tighten all pulley bushing bolts as outlined in the Douglas XT bushing manual. Tighten all bearing bolts. Secure all safety guards.
- Remove the steel guard around the AC motor (provided for shipping protection) and discard or recycle it. Have a licensed electrician provide wiring to the AC motor for 230 or 460 volts, 3 phase, 60 hertz. Ensure that the connection is properly grounded.

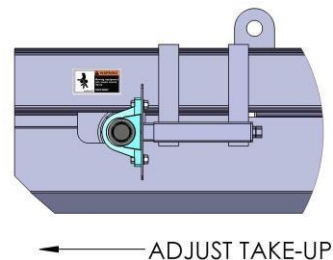

- Check correct rotation of the motor by jogging the control. The cleated belt should travel in a counter-clock-wise direction if the drive pulley is on the right. If the drive pulley is on the left the belt should travel in a clock-wise direction.
- After installing the cross-belt magnet in its operating location, power it up for about 5 seconds and immediately stop it for inspection. Check for belt tracking, proper component operation, loose bolts and any other problem that may appear. Listen for abnormal noise, vibration or other sounds that may indicate a problem. Immediately correct any such occurrence.
- Always turn on the self-cleaning permanent unit before turning on the conveyor to ensure the proper cleaning of the magnet.
- The ferrous tramp metal(s) will be discharged in a forceful manner at the drive pulley. Be sure to clear, guard and mark an area wide enough to prevent the discharged metal from causing personal injury or property damage. A diverter chute of UHMW or stainless steel can be installed adjacent to the discharge pulley to divert the ferrous metal to a desired location.

## **LUBRICATION**

- The worm gear reducer is shipped pre-lubricated with synthetic oil. Check the oil level every 3 months.
- The AC motor is pre-lubricated & sealed for life at the factory. Therefore, lubrication of the motor bearings is not required.
- The ball bearing pillow blocks should be greased every 3 months using standard lithium based No. 2 grease. Doing so will purge contaminants from the housing & bearing seals.

If you have any questions about the operation of your cross-belt magnet, call Douglas Manufacturing at any time during normal business hours.

Thank you for choosing a Douglas Ultra Strong Cross-Belt Magnetic Separator. We want it to give you years of low cost and safe service.

## DECAL LOCATIONS

If during routine inspections you discover missing items such as the name plate, logos, and caution or warning decals please contact Douglas Manufacturing as soon as possible to request replacements. Use the diagram below when you are ready to reattach them.

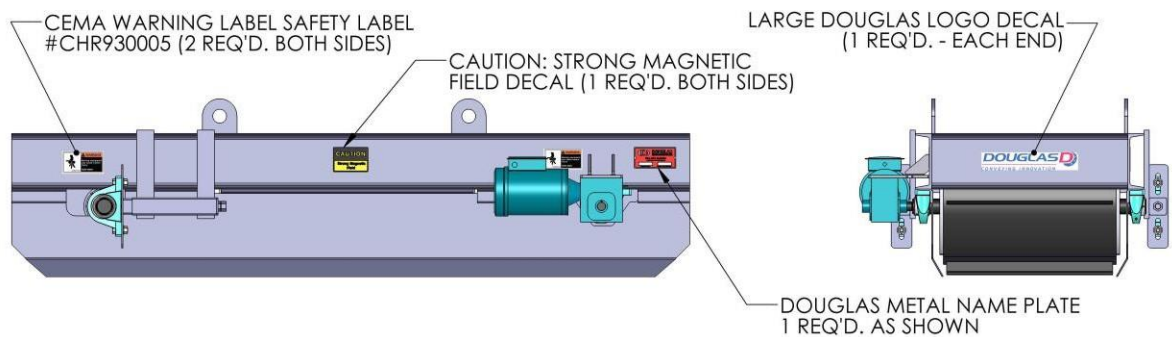

## OTHER MAINTENANCE ITEMS

Drive Pulley Lagging: regularly inspect the vulcanized rubber lagging on the drive pulley for cracks, tears or missing sections. The drive pulley was manufactured with a ¼” thick machined crown to facilitate belt tracking. Have the drive pulley lagging replaced as soon as possible when you notice any of these occurrences. Maintaining the drive pulley lagging will ensure that the cleated belt will track on center.

Cleated Belt Tracking: “Tracking” or training is defined as the procedure required to make the conveyor belt run “true” during normal operating conditions. Douglas has provided this Self-Cleaning Magnetic Separator with CEMA class crowned face drum pulleys. In addition, the drive pulley has been supplied with machine crowned ¼” thick smooth lagging to assist with belt tracking. Tracking the cleated conveyor belt is a process of adjusting the take-ups on the tail (non-driven) pulley. Use small turns of the take-up nut so as not to over-track the belt. The tracking adjustment is done while the belt is running. The adjustment(s) you make may not be immediately apparent, so permit the belt to run for several minutes to determine if additional adjustment is required.



### **Basic/Primary Rule of Tracking**

The basic and primary rule which must be kept in mind when tracking a conveyor belt is simple, **“THE BELT MOVES TOWARD THAT END OF THE PULLEY IT CONTACTS FIRST.”**